

Evaluation of safety countermeasures at intersections using microscopic simulation

Flávio Cunto

Research Assistant
- Department of Civil
Engineering
University of Waterloo 200,
University Street West, N2L
6P6
Waterloo, ON.
fjccunto@uwaterloo.ca

Frank F. Saccomanno

Professor – Department of
Civil Engineering, University
of Waterloo 200, University
Street West, N2L 6P6,
Waterloo, ON.
saccomm@uwaterloo.ca

Resumo

Na maioria das jurisdições, cerca de 40% das colisões em rodovias ocorre em, ou próximo a interseções. A necessidade de reduzir estas colisões motivou pesquisas consideráveis sobre o desenvolvimento e a avaliação de medidas preventivas efetivas de baixo custo. Os engenheiros de segurança têm tentado tomar decisões que afetam a segurança baseada no conhecimento extraído dos tipos diferentes de modelos estatísticos e/ou de observação antes e após a análise. Reconhece-se que, geralmente, este tipo de conhecimento não está disponível estatística ou empiricamente. O uso da simulação microscópica do tráfego nas últimas duas décadas focalizou essencialmente a análise da eficiência do transporte de sistemas com interseções sinalizadas, redes arteriais e auto-estradas. O potencial da simulação microscópica na segurança de tráfego na análise do conflito do tráfego foi reconhecido por Darzentas et al. (1980) e tem gerado interesse crescente em anos recentes. Este artigo introduz um modelo comportamental em micro-nível para estimar o potencial de colisões em interseções, para diferentes cenários de tráfego e atributos geométricos baseados na taxa de desaceleração com o objetivo de evitar a colisão (DRAC) e, a taxa disponível máxima da desaceleração (MADR). O modelo foi aplicado em um contorno simples a esquerda para uma interseção de quatro saídas, sem sinalização. Para esta situação, foram observados os incrementos em tempos de percepção, reação do motorista e, redução na fricção da superfície do pavimento, com o incremento potencial colisões. O artigo investiga como o modelo pode ser usado para fornecer introspecções na redução de colisões com a presença de sinalização.

Palavras-chave: Colisões. Segurança de tráfego. Desaceleração.

Abstract

In many jurisdictions, over 40% of all road crashes take place at or near intersections. The need to reduce these crashes has fostered considerable research on the development and evaluation of cost-effective countermeasures. Safety engineers have been trying to make decisions affecting safety based on the knowledge extracted from different types of statistical models and/or observational before-after analysis. It is generally recognized that this type of factual knowledge is not easily obtained either statistically or empirically. The use of microscopic traffic simulation over the last two decades has essentially focused on the analysis of system transportation efficiency such as signalized intersections, arterial networks and freeway corridors. The potential of microscopic simulation in traffic safety and traffic conflict analysis was initially recognized by Darzentas et al (1980) and has gained increasing interest in recent years. This paper introduces a micro-level behavioural model to estimate crash potential at intersections for different traffic scenarios and geometric attributes based on deceleration rate to avoid the crash (DRAC) and the maximum available deceleration rate (MADR). The model has been applied to a simple left turn movement for a four-leg unsignalized intersection. For this situation, increases in driver perception and reaction times and reduction in the pavement surface friction were found to increase crash potential significantly. The paper speculates on how the model can be used to provide insights into crash reduction resulting from signalization.

Keywords: Crash. Traffic safety. Deceleration.

1 Introduction

Intersections are a critical component of road safety. In Ontario, about 45% of reported crashes for 2002 took place at or near intersections (Ontario Road Safety Annual Report, 2002). The need to reduce these crashes has fostered considerable research on the development and evaluation of cost-effective countermeasures based on improvements in intersection geometry and real-time traffic control. (Persaud *et al*, 2003, Zennaro and Misener, 2003, Cody, 2005)

Geometric improvements include countermeasures such as the construction of exclusive or dedicated left-turn and right turn lanes, improvements in turning radii and removal of obstacles in the vehicle trajectory. These types of improvements could include capital intensive “grade separation” options or the replacement of intersections with roundabouts. Real-time traffic control attempts to modify the pattern of traffic conflicts at intersections by providing directional vehicle guidance that could have significant potential to reduce certain types of crashes. These controls could include the introduction of signal devices with a range of directional protocols and advanced driving warning systems that are operational in real time.

Before introducing a given countermeasure at an intersection, the net safety gain (crash reduction) of this option needs to be established *vis-à-vis* its implementation cost for different geometric and traffic conditions. Safety engineers have been trying to make decisions affecting safety based on the factual knowledge extracted from different types of statistical models and/or observational before-after analysis. It is generally recognized that this type of factual knowledge is not easily obtained either statistically or empirically. Davis (2004) and Hirst et al. (2004) cite a number of shortcomings associated with these types of approaches as applied to the evaluation of countermeasures at a specific location over different periods of time. These include:

1. Discrepancies between predicted and actual crash rates following the implementation of a countermeasure could occur normally as a result of historical trends in crash occurrence regardless of the countermeasure. This is frequently referred to as the “regression-to-the-mean” phenomenon.
2. These methods fail to consider driver behavioural factors and other variables that influence a site’s level of safety.
3. Variables that are identified as being potentially significant for reducing crashes may fail to meet minimum thresholds for inclusion in statistical models. Their contribution to crashes may be plagued by problems of co-linearity.
4. Due to the rare random nature of crashes and data availability, the effect of an important variable may not be large enough to be detected reliably in a before and after observational data, despite the fact that its effect cannot be denied intuitively.
5. Under-reporting of crashes in police reports, especially those with low severity and failure to consider “near misses”.
6. Mis-specification of the causes and consequences of the crashes in the historical data.

The use of microscopic traffic simulation over the last two decades has essentially focused on the analysis of transportation efficiency such as signalized intersections, arterial networks and freeway corridors. The potential of microscopic simulation in traffic safety and traffic conflict analysis was initially recognized by Darzentas et al (1980) and has gained increasing interest in recent years. According to Archer (2000), existing micro-simulators are not designed for safety assessment due to the complex and multi-disciplinary nature of road-user behaviour. Furthermore, available car-following, gap-acceptance and lane change models are sufficient to represent driver behaviour in a “normative” way. To evaluate the safety demands one might need a more complex driver behaviour model with a higher level of variance including errors in the driver’s perception, decision-making and action process.

Crashes represent a complex hierarchical process of inter-related causes and consequences for different driving situations, locations and time intervals. Therefore, a complete picture of lack of safety at a given location only emerges following a detailed “mechanistic analysis” of the causes and consequences of crashes at a given location and point in time at a given location and point in time. For a highly circumscribed crash (e.g. rear-end crashes in non-merging freeway flows without lane changes, left turn manoeuvres at intersections, etc), researchers are beginning to explore different mechanistic approaches that can provide valuable insights into how crashes take place with their corresponding likelihood of occurrence (Mehmood *et al.*, 2002 and Cody, 2005).

2 Objectives

A micro-level mechanistic analysis of vehicle movements can account for different driving and traffic conditions, including changes in the average daily traffic volume, effect of driver behaviour, road geometry and different intersection control devices (e.g. AWST, TWSC, conventional fixed cycle traffic signals).

The research described in this paper has two specific objectives:

1. Develop a micro-level traffic simulation model that can identify potentially unsafe vehicle interactions for different vehicle movements based on three types of traffic behaviors protocols, car-following, lane change and gap acceptance.
2. Link the traffic simulation model to a Crash Potential (CP) component based on real-time analysis of traffic conflicts for different vehicle movements, driver perception and reaction times, and vehicle speed/deceleration profiles.

The paper includes a discussion of potential model application to assess the safety implications of intersection traffic signalization.

2.1 Defining traffic conflicts at intersections

The usual representation for considering crashes at intersections is based on identifying “traffic conflicts” for various vehicle movements. A traffic conflict is defined as a juxtaposition of vehicle trajectories (more than one vehicle occupying the same space at the same time). Potential traffic conflicts are determined using micro level simulation and the overall lack of safety at intersections can be obtained using three components of driver behaviour: car-following, lane-changing and gap-acceptance. Such an approach was considered by Archer (2000), Minderhoud and Bovy (2000), Kosonen and Ree (2001) and Barceló, et al (2003) and Gettman and Head (2003) in their analysis of surrogate safety indicators using traffic simulation models.

As illustrated in Figure 1, the identification of potential traffic conflicts is determined for a simple left turn movement where the left turn vehicle enters the intersection from the minor approach in the northbound direction. The LT vehicle is referred to as the Target Vehicle (TV), since it initiates the process leading to a potential crash at the intersection. The risk associated with this LT movement begins the moment that TV decides to proceed through the intersection after coming to a full stop (Pt. A in Figure 1). The left turn manoeuvre for the TV is defined in terms of two phases: 1) Gap-acceptance for the vehicle entering the intersection from pt. A *vis-à-vis* eastbound vehicles proceeding through the intersection along the major road in both lanes. 2) Gap-acceptance of the TV moving into the westbound lanes from the center median storage area *vis-a-vis* westbound vehicles proceeding through the intersection into the median westbound lane.

Vehicles proceeding through the intersection along the major road are considered as Response Vehicles (RV), since their drivers react or respond to the actions of the TV driver. In this hypothetical exercise only three RV movements are considered: eastbound vehicles travelling in both the near side and centre median lane, and westbound vehicles travelling in the center median lane. Initially, we ignore all potential rear end and head-on crashes situations that result from secondary vehicle interactions and/or southbound vehicles running the stop sign on the minor approach.

As illustrated in Figure 1, for a simple LT case potential crashes are assumed to result from erroneous RV actions taken in response to TV stimuli. Traffic conflicts leading to a potential crash arise during three time-space intervals: 1) TV traverses the near side eastbound lanes in reaching the centre median storage area, 2) TV obstructs flow in the eastbound center median while it awaits a suitable gap in the center median westbound lane, and 3) TV enters the centre median westbound lane if a suitable gap arises creating a potential conflict with vehicles travelling westbound on the major road. In this example it is assumed that the TV driver speculates on the distance and time-to-crash posed by the various response vehicles using insights gained from observed average speeds, headways and assumptions about RV driver behaviour.

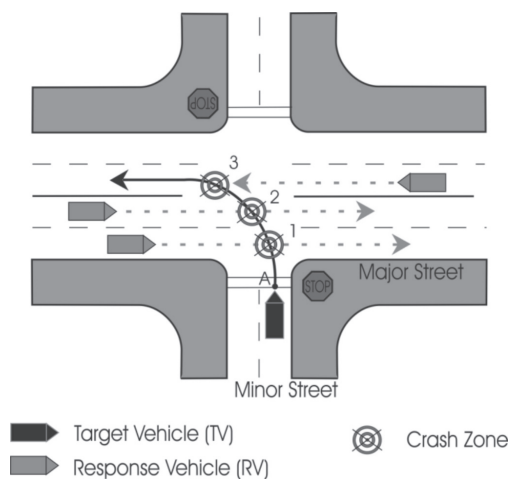

Figure 1: Single conflicting interaction for a left-turn manoeuvre

2.2 Crash potential relationships

A crash potential (CP) arises when the response vehicle (RV) deceleration rate needed to avoid a crash (DRAC) with the TV exceeds the RV maximum allowable deceleration rate (MADR). DRAC is determined over the simulation in 0.1 sec time intervals using actual RV speeds and distances established with respect to the “crash zone”. Those values will be affected by the driver’s reaction time once the sooner the evasive action begins (braking) the lower will be DRAC. This paper assumes that drivers can apply correctly the deceleration rate needed stop the vehicle before the crash zone. The crash zone as shown in Figure 1 reflects an area in the intersection where the target vehicle (TV) trajectory overlaps with the expected trajectory of each RV. As defined in this paper, the crash zone is assumed to form a discrete time-space window associated with each traffic conflict. The size of this window will depend on the relative speeds and dimensions of the vehicles and the lane width.

Logically we would assume CP to vary with respect to differential vehicle speeds, accelerations and spacing. For example, vehicles with higher speed differentials travelling close to each other are more likely to be involved in crashes than vehicles with lower differential speeds travelling further apart. This relationship needs to be explored in more depth. For this paper, we have assumed that CP for a specific vehicle is expressed in terms of the accumulated time in which DRAC surpassed MADR, therefore

$$C P_i = \sum^{T_i} b \cdot \delta t \tag{1}$$

Where:

CP_i = crash potential for vehicle i (seconds)

b = state variable, 1 if $DRAC > MADR$ in a specific time interval, 0 otherwise

δt = simulation time interval (0.1s)

T_i = total simulation time for vehicle I

The applicability of others safety indicators found elsewhere will be investigated, such as deceleration to safety time (DTS), post-encroachment time (PET), potential time to collision (PTTC), time exposed time to collision (TIT) and time to accident (TTA), (Archer, 2000, Minderhoud and Bovy, 2000, Kosonen and Ree 2001, Barceló et al., 2003 and Gettman and Head, 2003).

For a situation where the RV and TV are travelling in the same direction, the RV will not have to come to a full stop, but simply needs to match the speed of the TV in order to avoid the crash. For the case of RV and TV trajectories intersecting at some angle greater than zero, the RV speed needs be set equal to zero (stop). MADR is estimated using individual RV driver perception and reaction times and fundamental information concerning coefficients of friction based on prevailing pavement surface condition, tires and type of RV braking system.

Based on the definition of crash potential and actions taken by the TV driver, Figure 2 provides a framework to establish CP in real-time using micro-level simulation. In order to establish this potential, the algorithm shown in this Figure can be applied repeatedly to different time intervals until the TV clears all three crash zones as defined by the gap acceptance algorithm.

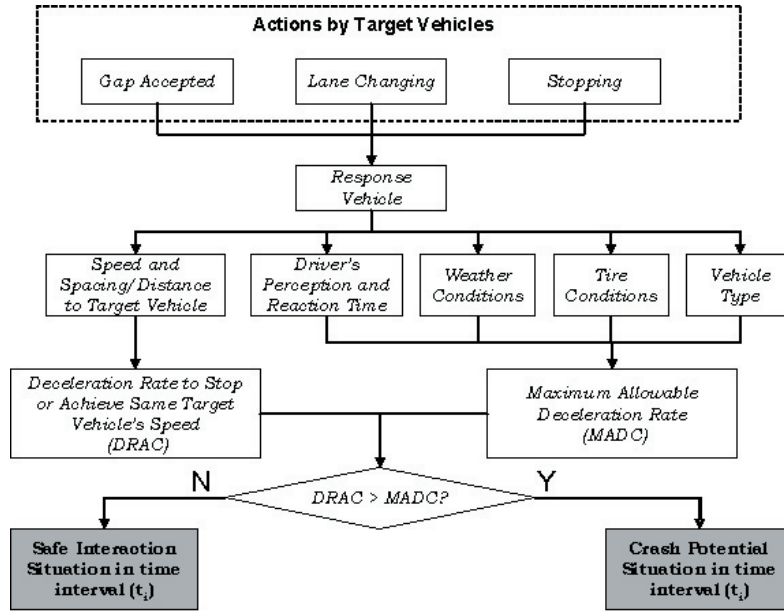

Figure 2: Framework to determine a crash potential situation in time (t_i)

The above discussion has focused on a simple LT vehicle movement from the minor approach. The Highway Capacity Manual (HCM) identifies 12 different vehicle movements for a typical four-leg intersection as showed in Figure 3. Each of these movements will need to be modeled separately. Table 1 summarizes the traffic conflicts considered to establish crash potential for unsignalized intersections for the 12 movements cited in the HCM (2000) based on car-following, lane change and gap acceptance algorithms. For this analysis only TV movement 7 and RV movements 2 and 5 are considered.

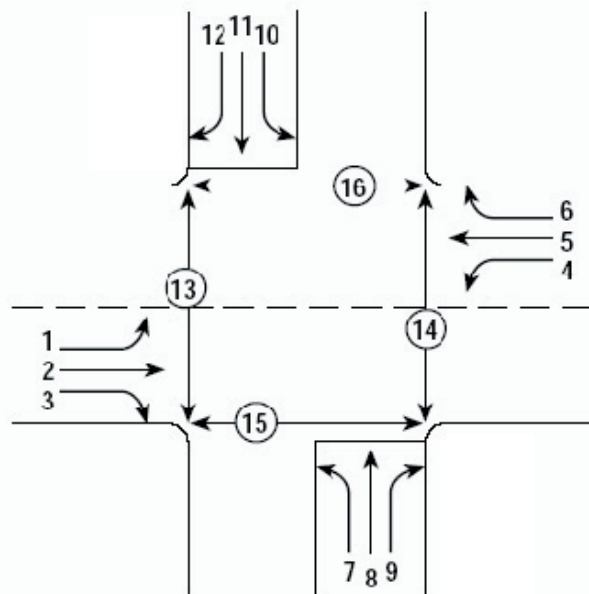

Figure 3: General manoeuvre numbering scheme for a four-legged intersection (Source: HCM 2000)

The movements in Table 1 are for unsignalized intersections. The introduction of a traffic signal will alter the CP for each relevant RV movement in this Table. For an unsignalized intersection, the potential for a crash results from the RV on the major road being in conflict with the left-turn TV entering the intersection from the minor approach. For a signalized intersection, crash potential arises as a result of a rear end crash situation between vehicles moving on the major approaches stopping for the traffic light, acting as separate targets for vehicles moving in the same direction.

On the minor approach many critical gap-acceptance situations would be eliminated considering that vehicles seeking gaps now have a specific green phase on which to proceed. However, interactions between approaching vehicles and stopped vehicles on the minor approach are present for both signalized and unsignalized cases. For the signalized case the difference would be the in number of interactions which depend on available gaps and on the traffic signal cycle (red/green/amber etc).

The RV is at risk of a crash with the left turning TV if the time required to complete each stage of the left turn movement exceeds the minimum time required for RV to reach the crash zone. The latter is based on observed vehicle location and speed/deceleration capabilities.

In the next section of the paper, micro-level simulation is used to explore the above left turn movement in terms of changes in CP for the unsignalized intersection case. The implications of introducing a directional traffic signals at the intersection will then be discussed.

Table 1: Crash potential situations and pertinent micro-level models for unsignalized intersection

Movement	Target Vehicle (TV) Manoeuvre/Action	Response Vehicle (RV) movements involved and micro-level model used to represent		
		Car-following (CF)	Lane-Change (LC)	Gap-acceptance (GA)
1	Decelerate to adequate speed to begin left turn	1, 2	-	-
	Turn left when gap is accepted.	-	-	5, 6
2	Decelerate to adequate speed when traveling on median lane due to movement 1.	1, 2	-	-
	Change lane when traveling in median lane to avoid excessive delay due to movement 1	-	2, 3	-
3	Decelerate to adequate speed to begin right turn manoeuvre.	2, 3	-	-
4	Decelerate to adequate speed to begin left turn	4, 5	-	-
	Turn left when gap is accepted.	-	-	2, 3
5	Decelerate to adequate speed when traveling on median lane due to movement 4.	4, 5	-	-
	Change lane when traveling in median lane to avoid excessive delay due to movement 4	-	5, 6	-
6	Decelerate to adequate speed to begin right turn manoeuvre.	5, 6	-	-
7	Decelerate to stop and wait for a acceptable gap.	7, 8, 9	-	-
	Turn left when gap is accepted.	-	-	1, 2, 4, 5
8	Decelerate to stop and wait for acceptable gap.	7, 8, 9	-	-
	Proceed straight ahead when gap is accepted.	-	-	1, 2, 4, 5, 6
9	Decelerate to stop and wait for acceptable gap.	7, 8, 9	-	-
	Turn right when gap is accepted.	-	-	2
10	Decelerate to stop and wait for a acceptable gap.	10, 11, 12	-	-
	Turn left when gap is accepted.	-	-	1, 2, 4, 5
11	Decelerate to stop and wait for acceptable gap.	10, 11, 12	-	-
	Proceed straight ahead when gap is accepted.	-	-	1, 2, 3, 4, 5
12	Decelerate to stop and wait for acceptable gap.	10, 11, 12	-	-
	Turn right when gap is accepted.	-	-	5

3 Simulation results

The preliminary analysis presented in this work comprises a set of 4 scenarios each one with 1 hour simulation time. The specific scenarios are:

1. Alert drivers and wet pavement, worn tires with a perception and reaction time of 0.75 secs and a coefficient of friction between tires and pavement of 0.38
2. Alert drivers and dry pavement, good tires with a perception and reaction time of 0.75 secs and a coefficient of friction between tires and pavement of 0.78
3. Non alert drivers and wet pavement, worn tires with a perception and reaction time of 1.50 secs and a coefficient of friction between tires and pavement of 0.38
4. Non alert drivers and dry pavement, good tires with a perception and reaction time of 1.50 secs and a coefficient of friction between tires and pavement of 0.78. For this simulation a volume on the major approach of 400 vphpl was assumed

Table 2 summarizes the different drivers perception-reaction times and weather characteristics used in each scenario. The simulation algorithm was implemented in visual basic. Table 3 presents the number of vehicles involved and the number of seconds under CP for each of the scenarios described above.

Table 2: Different drivers and weather characteristics used on the simulations

Scenario	RV Average Perception and reaction time (s)	Average Coefficient of friction	Volume on major (vphpl)	Obs
1	0.75	0.38	400	Alerted drivers, wet pavements and worn tires
2	0.75	0.78	400	Alerted drivers, dry pavement and good tires
3	1.5	0.38	400	Un-alerted drivers, wet pavement and worn tires
4	1.5	0.78	400	Un-alerted drivers, dry pavement and good tires

In order to run the simulation and evaluate CP the following assumptions were made:

1. Time headways were generated according to Poisson distribution. Individual RV speeds were generated using a Normal distribution with an average speed of 40km/h with a standard deviation equal to 20% of the mean. This situation reflect speeds of 80km/h for free-flow conditions and a jam-density following Greenshield’s model of 80 vehicles/km per lane.
2. Perception and reaction times and coefficients of friction that follow a Normal distribution with a mean as shown in Table 1 and standard deviation equal to 20% of the mean.
3. To calculate the perceived time for the RV to reach the crash zone and therefore decide if the gap is acceptable or not, TV is assumed to use clues from the average speed of vehicles on the major approach and the distance to the crash zone plus. A given distance perception error fixed at 20% was used to reflect overall depth perception problems faced by drivers. This error needs to be further investigated and existing gap-acceptance models can also be applied on that matter.
4. The true time required for the TV to clear the crash zone is determined using a fixed acceleration rate of 5.3 km/h per sec, lane widths of 3.5m, uniform car length equals to 4 meters and distance from the front bumper to the intersection approach line of 1m.
5. The perceived time for the TV to clear the crash zone is assumed to be the true time to clear the crash zone reduced by a perception error of 20%.
6. A specific gap is accepted if the perceived time needed for the TV to clear the crash zone is less than the perceived time for the RV to reach the same crash zone.

Table 3: Results summary for different simulated scenarios

Results	Scenario 1	Scenario 2	Scenario 3	Scenario 4
# vehicles in potential crash situations shoulder lane – WB	14	6	18	6
# vehicles in potential crash situations median lane WB	4	-	19	4
# vehicles in potential crash situations median lane EB	6	5	14	4
# Gaps accepted	138	150	158	158
# Generated vehicles	1466	1441	1494	1506
CP(secs)	36.6	6.8	57.7	10.1
% of simulated time under CP	1.02	0.19	1.60	0.28
CP/Veh (sec/veh)	0.025	0.005	0.038	0.007

Several important results can be noted for the unsignalized intersection based on the safety indicator crash potential divided by the number of generated vehicles (CP/Veh) in Table 3

- When the perception and reaction time is increased from 0.75 to 1.50 seconds, CP increases by a corresponding 52% for wet pavement and worn tire conditions, and 40% for dry pavement and good tire conditions.
- When pavement friction is reduced from 0.78 to 0.38, CP will increase by 400% for perception and reaction time of 0.75 seconds (alert drivers) and over 443% for a perception and reaction time of 1.5 seconds (non alert drivers).
- At the two extremes, for the best case scenario 2 (0.75 seconds perception and reaction time and 0.78 coefficient of friction) CP is flagged for 6.8 secs of simulation, as compared to the worst case scenario 3 (1.50 seconds perception and reaction time and 0.38 coefficient of friction) where CP is flagged for 57.7 secs of simulation time. This reflects a significant increase in CP risk of over 650%.

Expected Changes in CP for a Signalized Intersection

The introduction of a traffic signal will eliminate many crash potential situations initiated by vehicles in movement 7 (attempting to turn left) since it reserves a specific un-conflicted time interval (directional green time) for each left turn movement. However, during the general green time vehicles attempting to turn left still have to wait for an acceptable gap from vehicles in the southbound approach. Obviously conditions that produce a CP must change for all movements. Table 4 summarizes what is considered to change in TV movements (actions) and the expected influence on CP when the intersection is upgraded from unsignalized to signalized. Implications presented in Table 4 as well as the conditions that produce change in CP for the complete set of movements in the unsignalized and signalized case needs to be explored in more depth.

4. Conclusions

The use of micro-level behavioural models can provide valuable insights regarding the evaluation of safety at intersections subject to the introduction of signalization for different geometric, operational and environmental conditions. However, a considerable amount of research is needed to establish a safety indicator that could be reasonable linked to “real” traffic crashes, and the calibration and validation of the emerging micro-level “safety” models remains an open question.

This paper presents some preliminary results of a micro-level mechanistic model of intersection vehicle movements. The model can be used to identify potential traffic conflicts and establish corresponding CP measures for different vehicle interactions and traffic conditions. In this paper CP was assumed to take place when the perceived TV time intervals for crash avoidance exceeds actual time available for the given traffic conditions and RV volumes. The introduction of a traffic signal is expected to make average deceleration manoeuvres to turn left/right more disciplined particularly during directional green phases, hence providing safer interactions. However, straight movements in the major street should face a new interaction between themselves due to mandatory stop by amber/red phase. This model can serve as a practical guide to decision makers considering a range of countermeasures including signalization at a given intersection.

5. Acknowledgements

This research was supported in part by a contribution from the Ministry of Transportation of Ontario. Opinions expressed in this report are those of the authors and may not necessarily reflect the views and policies of the Ministry of Transportation of Ontario. We are also appreciative of the comments and suggestions provided by Professor Bruce Hellinga of the University of Waterloo.

References

- Ontario Road Safety Annual Report 2002 (ORSAR). Ministry of Transportation of Ontario. Ontario. http://www.mto.gov.on.ca/english/safety/orsar/orsar02/chp3_02.htm#3c. Accessed July 14, 2005.
- PERSAUD, B., McGee, H., Lyon, C. and Lord, D. Development of a Procedure for estimating the Expected Safety Effects of a Contemplated Traffic Signal Installation. Presented at 82nd Annual Meeting of the Transportation Research Board, Washington, D.C., 2003.
- ZENNARO, M., Misener, J. A “state map” architecture for safe intelligent intersections. In: *Proceedings of the 13th Annual Meeting of the Intelligent Transportation Society of America*, Minnesota, May, 2003.
- CODY, D. Analysis of exploratory field test data from a instrumented vehicle: description of the left turn maneuvers for intersection safety countermeasure design. Presented at 84th Annual Meeting of the Transportation Research Board, Washington D.C., 2005.
- DAVIS, G.A. Possible Aggregation Biases in Road Safety Research and a Mechanism Approach to Accident Modeling. *Accident Analysis and Prevention*. Vol. 36, 2004, pp. 1119-1127.
- HIRST, W.M., Mountain, L.J., Maher, M.J. Sources of error in road safety scheme evaluation: a method to deal with outdated accident prediction models. *Accident Analysis and Prevention*. Vol. 36, 2004, pp 717-727.
- DARZENTAS, J., Cooper, D. F., Storr, P.A., McDowell, M.R.C. Simulation of road traffic conflicts at T-junctions. *Simulation*. 1980, pp. 155-164.
- ARCHER, J. Developing the potential of micro-simulation modelling for traffic safety assessment. In: *Proceedings of the 13th ICTCT Workshop*. Corfu, 2000.
- MEHMOOD, A., Saccomanno, F., Hellinga, B. Simulation of Road Crashes by Use of System Dynamics. In *Transportation Research Record, No. 1746*, TRB, National Research Council, Washington, D.C., 2002.
- MINDERHOUD, M., Bovy, P. Extended time to collision measures for road traffic safety assessment. *Accident Analysis and Prevention*. Vol. 33, 2001, pp 89-97.
- KOSONEN, I., Ree, S. The potential for microscopic simulation in traffic safety and conflict studies. In *Proceedings of Conference on Road Safety on Three Continents*. Pretoria, 2000.
- BARCELÓ J., Dumont, A., Montero, L., Perarnau, J., Torday, A. Safety indicators for microsimulation-based assessments. Presented at 82nd Annual Meeting of the Transportation Research Board, Washington D.C., 2003
- GETTMAN, D., Head, L. Surrogate safety measures from traffic simulation models. Presented at 82nd Annual Meeting of the Transportation Research Board, Washington D.C., 2003
- Highway Capacity Manual 2000. Transportation Research Board. National Research Council, Washington, D.C., 2000.

ABOUT THE AUTHOR

Flávio Cunto

Research Assistant - Department of Civil Engineering University of Waterloo 200, University Street West, N2L 6P6 Waterloo, ON.

Frank F. Saccomanno

Professor – Department of Civil Engineering, University of Waterloo 200, University Street West, N2L 6P6, Waterloo, ON.